



VERNON



Hydraulic-Powered
Tube Expanding Equipment

The Vernon Model H Tube Expanding System

General Description

The Vernon Tube Expanding Machine, TXM, is designed to roll consistent, accurate tube to tubesheet joints in a production environment. The TXM consists of four major assemblies as described below:

- **Base Unit**

The TXM Base Unit includes the caster-mounted cabinet which houses the electric motor, the hydraulic pumps and hoses, the hydraulic oil tank and the control system. The Base Unit also contains hydraulic and electrical control panels for set-up and machine status.



- **Driver**

The Driver is the hand-directed assembly that provides the rotation and control of the tooling. The Driver Assembly includes the two-position operator's cycle control switch and the spring return pause button.

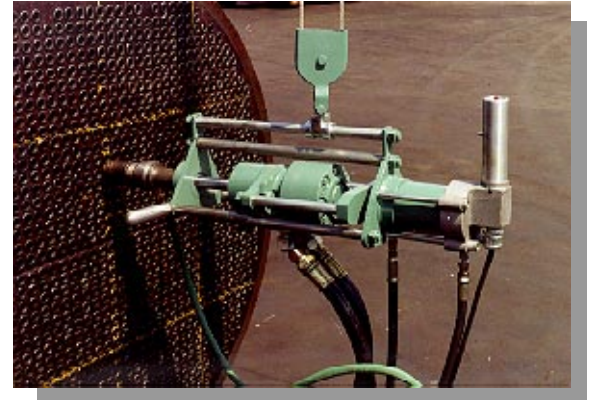

- **Mast Assembly**

The Mast Assembly includes the vertical post and the over head arm, together with the rope/pulley system. The purpose of the Mast Assembly is to support and position the Driver during rolling operations.



- **Tooling**

The tooling consists of the replaceable rolls, mandrels and cages used in the expansion operation. A complete set of rolls (usually three), together with the corresponding mandrel and cage is referred to as an expander.

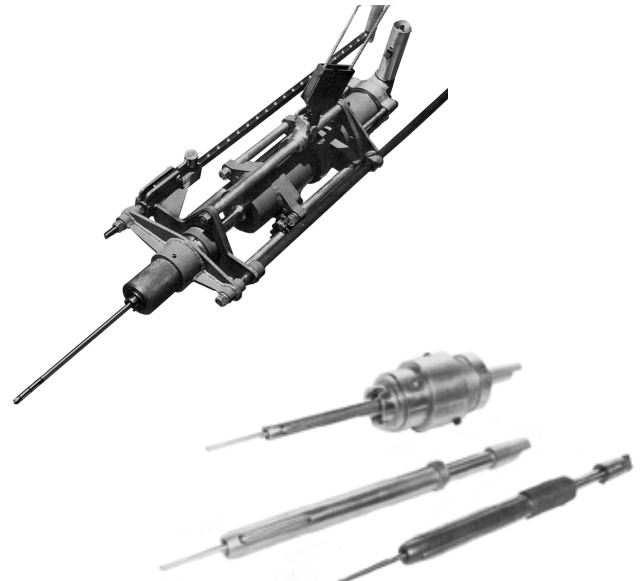

Features

- **Vernon's Design Increases Production**

Automatic axial movement eliminates time lost in reversing mandrel rotation for retraction. Even under load, the hydraulic system maintains a constant RPM.

- **Controlled Tube Joints**

Precision tube expansion is insured thanks to Vernon's "preset" design. Control of advancing force, rate of feed and torque on the mandrel are automatic, minimizing tube end and tube sheet distortion while producing a leak-proof joint.

- **Easy to Operate**

Press the cycle switch and the mandrel automatically advances in the expander, expands the tube and retracts for the next cycle.

- **Longer Tool Life**

Automatic tool lubrication, single direction rotation and greater roll-to-mandrel contact combine to lengthen tool life and lower operating cost.

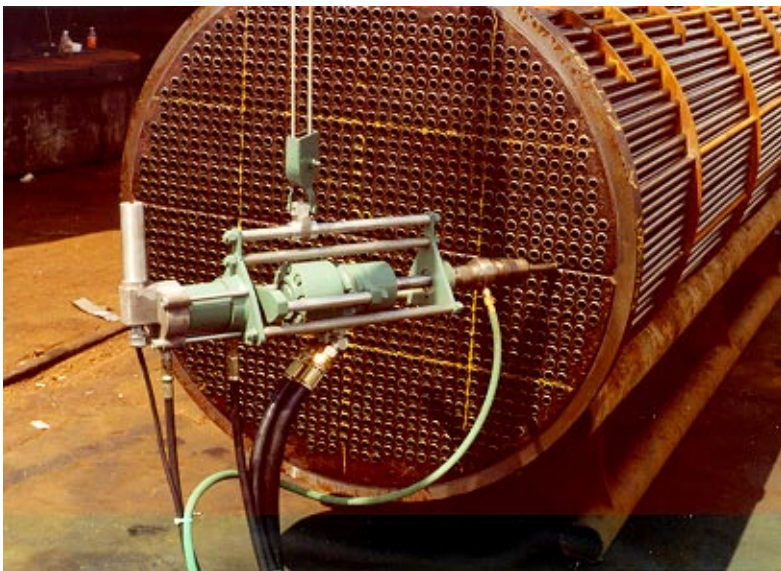

TXM Assembly

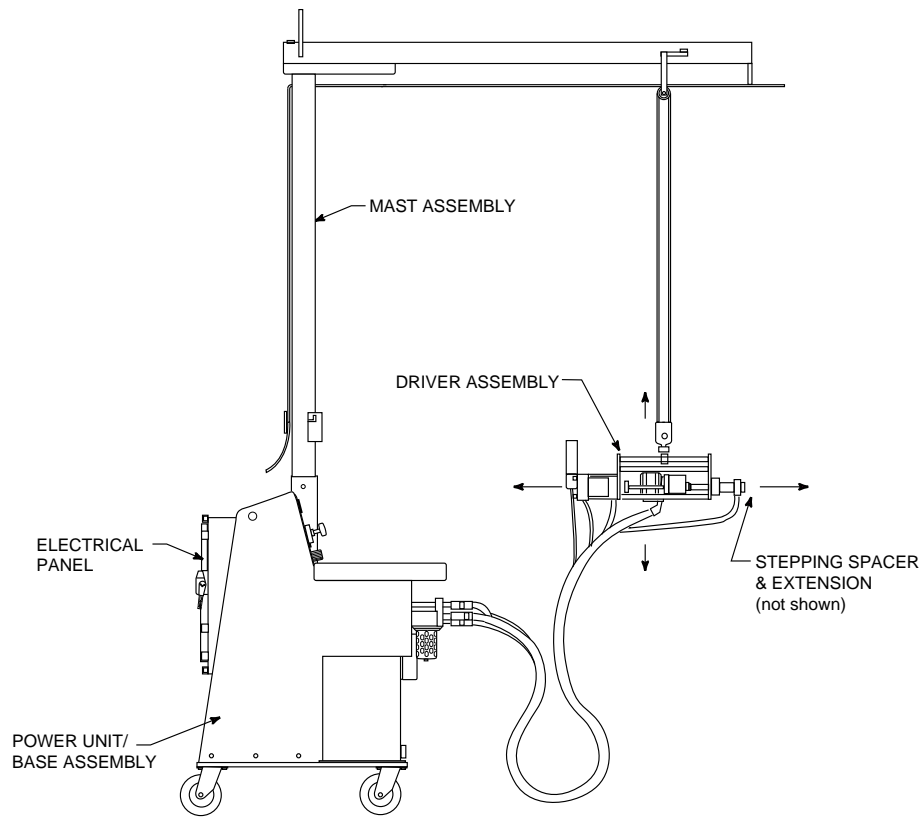

Model H Driver & Stepping Motor

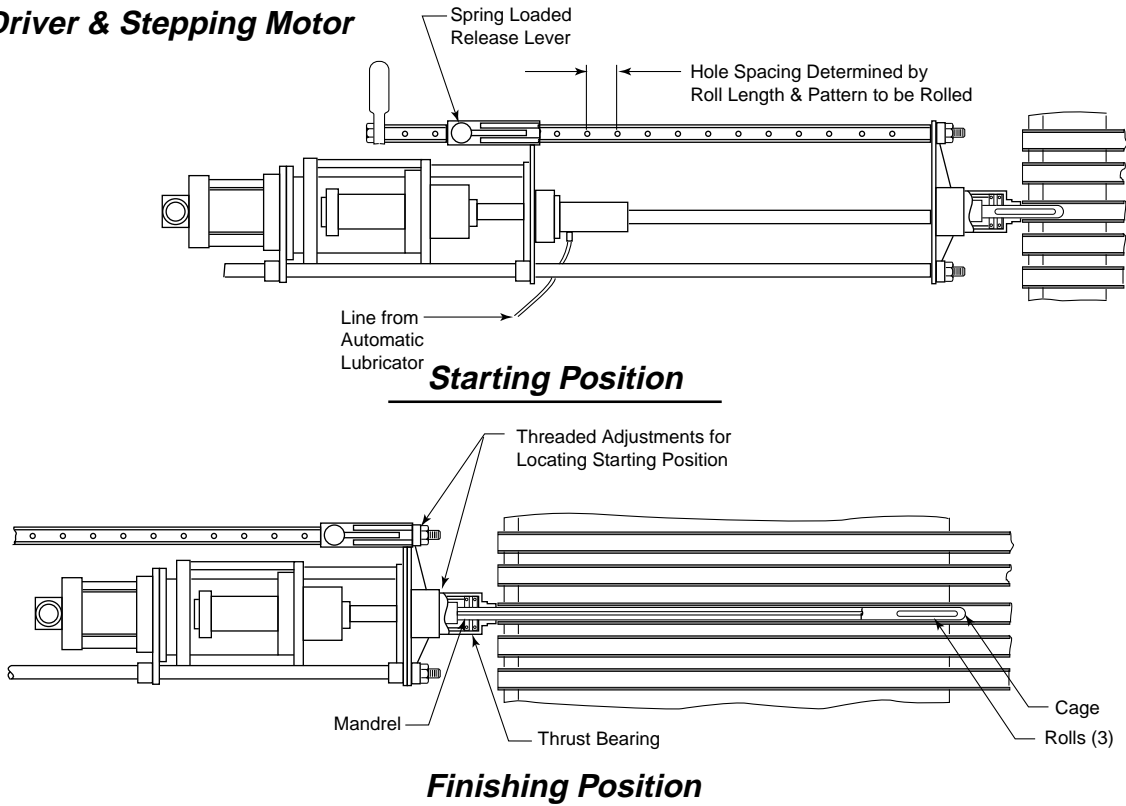

Vernon Tool Company

503 Jones Road, Oceanside, CA 92054
619.433.5860 • Fax 619.757.2233